

COLLECTING INFORMATION – SCREW TIP

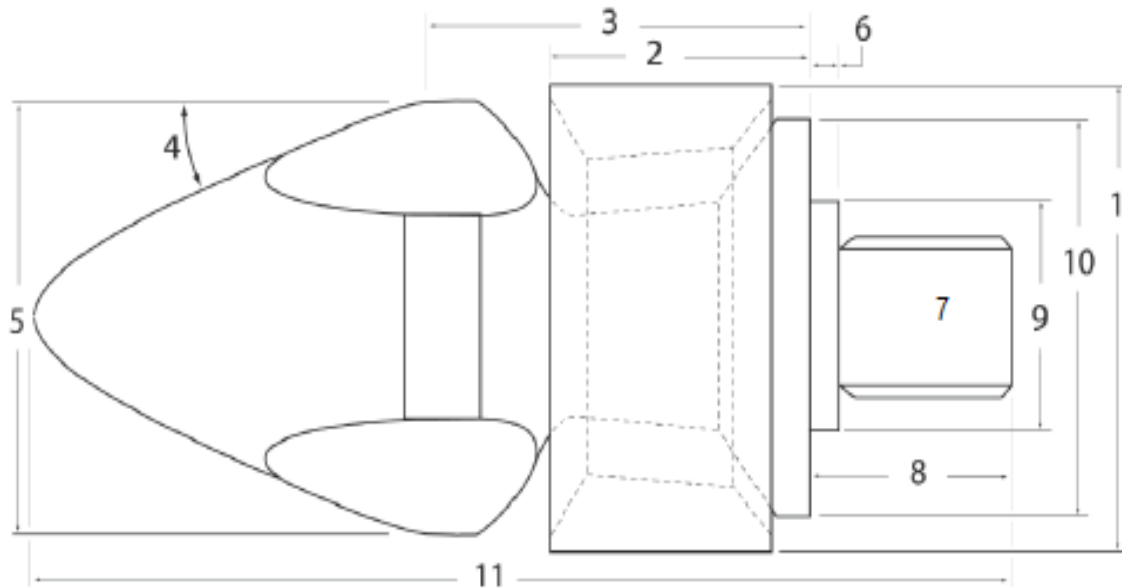

CUSTOMER		REFERENT	
BRAND MACHINE		YEAR	
TYPE		TONNAGE	
CODE REPLACEMENT		INJECTION UNIT	
PROBLEMS			
OTHER NOTES			
	Barrel Ø – 1		
	quota from behind the spacer up to the front of the valve – 2		
	quota from behind the turntable until the beginning of the conicity – 3		
	cone angle – 4		
	Ø of the cone – 5		
	thread length – 6		
	thread: indicate also if left or right – 7		
	quote from behind the spacer until the end of the thread – 8		
	centering Ø – 9		
	spacer Ø – 10		
	total length – 11		